

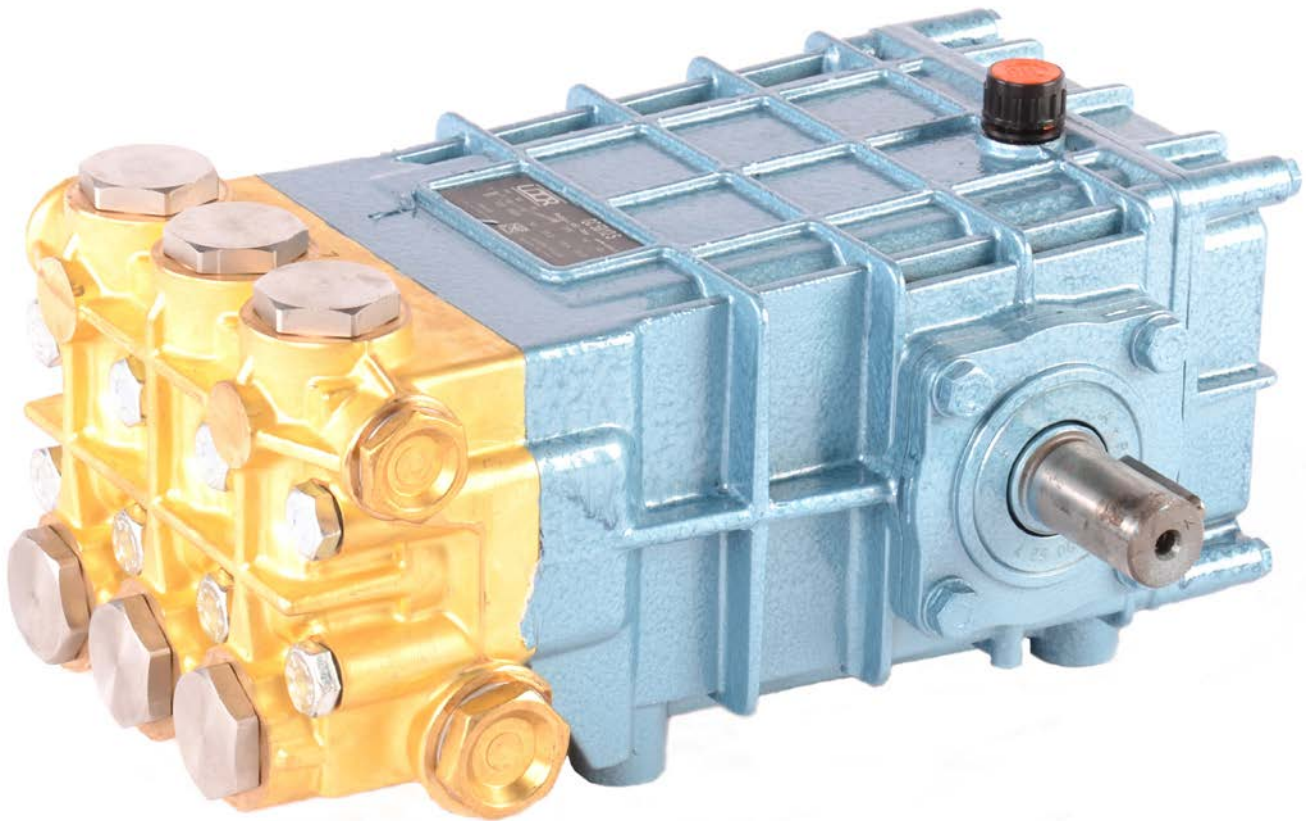

Horticultural Spraying Solutions

Operation manual

GC50



Empas B.V.
Kruisboog 43
3905 TE Veenendaal
+31(0)318-525888
www.empas.nl

Index

EC declaration of conformity	3
Technical data	4
General description	4
Possible drive options	4
Application	4
Function	4
General	4
Making the spray fluid	4
Spraying of the fluid or water	4
Safety instructions	4
General	4
Chemicals	5
Safety instructions in operation	5
General	5
Protections against chemicals	5
Change kind of chemicals	5
Filling	5
Electrical	6
Traffic safety	6
Operation	6
General	6
To fill the main tank	6
Adding and mixing (dissolving) the chemicals	6
Clean water tank (optional)	7
Start of the spray activities	7
To stop the spray activities	7
Storage of the equipment	7
Use during a freezing period	7
Maintenance	8
General	8
Electrical	8
Hydraulic parts, high pressure hoses etc.	8
Pump and valves	8
Fluid (water) pump circuit	8
The version with the Honda petrol engine	8
Fault finding	9
Attachments	10

EC Declaration of conformity

(according to appendix II.1.A of the machine directive 2006/42/EC)

Empas B.V. Kruisboog 43, 3905 TE Veenendaal, The Netherlands

Declares that the machine with the following specifications:

Machine name	
Type	
Serial number	
Construction year	

Complies with the provisions of the machine directive (2006/42/EC) and the extensions of it, the machine directive (2009/127EC), related to environmental requirements.

And declares further that standards mentioned below have been applied.

EMC directive (2004/108/EG) (if applicable for this specific machine)

.....
Low voltage directive (2006/95/EG) (if applicable for this specific machine)

.....
And declares also that (components of) the harmonised standard mentioned below has been applied:

NEN-EN-ISO 12100:2010

And declares in addition that the national standards mentioned below have been applied.

NVVK Standard P 169 high pressure cleaning with fluid (only for P> 100 bar)
Standard Vewin worksheet 3.8

Veenendaal, The Netherlands, date: 01-10-2017

Empas B.V., represented by:

H.G. Doornenbal, director

Signature:



Technical data

Type data on rating:

	Mach. no.:
	Type
	Max.: bar
	Q: L/min
Year of manufacture:	Pump rate:..... 1/min
	Weight: kg

General description

The EMPAS crop protection system exists generally out of:

A drivable and steerable vehicle frame on which are mounted:

- A store vessel for the spraying fluid (60-1500 litres) manufactured of polyethylene. This material is resistant to the applied chemicals.
- A high pressure pump driven by respective an electromotor, a petrol engine or a tractor.
- The necessary control handles respect. knobs.

Further optionally may be mounted:

- An electrically driven reel with a high pressure hose
- A spray gun
- A spray tree
- A spray standard
- A mixing injector
- A gauge
- A fourth wheel
- An electrical cord
- A clean water tank
- A cleaning system to clean the packaging of the to be added chemicals.

In figure 1 an example of an Empas spraying system is given.



Fig. 1

Possible drive options

If the spraying unit is driven by a combusting engine or a tractor, separate manuals are delivered for these parts.

Application

The EMPAS crop spray equipment is meant to supply vegetation of means of protection, disinfection remedy or feeding (also generally called: chemicals).

This happens by mixing, dissolving these chemicals in water and spraying in vegetation with the dissolvent with a relative high pressure.

The high pressure spray system is specifically meant for the agrarian (glass) horticulture. It can be applied indoors as well as outdoors.

It is not allowed to use the spray system for other applications.

Function

General

The purpose of the spray system is primarily to spray the vegetation with the chemicals added spray fluid. However she is also suitable to spray with normal clean water. In that case the pump is also able to suck water out of an external source.

Making the spray fluid

Before to be able to spray fluid, it has to be made. At first the tank must be filled with water via the closable opening on top of the tank. Subsequently the necessarily amount of chemicals must be supplied via this opening. After this, these chemicals will be dissolved and mixed in the water of the tank, till the fluid has become homogeneous.

Spraying of the fluid or water

After starting the high pressure pump (see fig. 2) the spray fluid is sucked from the fluid container (tank) by this pump, pressurized by this pump, and is sprayed via a flexible hose and spray gun, spray tree. The spray stand is suitable to spray clean water with 150-250 bar.

Safety instructions

General

Optimal attention is paid to the design and the manufacturing process of the equipment to prevent safety risks for the users as much as possible.

To emphasize the main precautions, diverse operation and warning stickers are affixed on the equipment. Take care these stickers will be kept readable and that they will not be removed.

The equipment must only be operated by persons with the age of 18 or older. They must have been familiarized with the equipment and have thoroughly knowledge of this user manual. All the, in this manual given instructions, must strictly be followed.

Further it is important that all users have also a good knowledge of this manual.

Be aware that local law may require a spray-licence for this equipment.

Take care the equipment is never operated by persons who are tired or influenced by alcohol or drugs.

If any part of this manual is unclear, don't hesitate to contact your EMPAS dealer. Do this before you are going to use the equipment.

Chemicals

When using (spraying with) chemicals, the legal safety precautions for these chemicals (they may be hazardous or toxic) must be taken into account.

Safety instructions in operation

General

- As a user you must be familiarised with the operation of the machine, especially how quickly to stop and depressurise it.
- Test the machine on pressure with clean water prior to the start of the machine operation.
- Never climb in the tank.
- Ensure always a stable position of the machine, taking into account all the (recoiling) forces on/from the machine respect. spray heads during the operation.
- Ensure always a stable fixed mounting of the spray tree, especially if it is necessary for a person to go under it.
- Do not ever point the high pressure spray gun on people or animals.
- Preferably keep the work area totally free of other people.
- Grab the spray gun firmly, taking into account the reaction forces of the spray head.
- Never clamp or block the handle of the spray gun during the operation.
- Never pull on the high pressure hose to relocate the machine (risk on damage of the hose and/ or the hose couplings).
- Do not cover the machine during operation.
- It is not allowed to operate in small rooms with insufficient ventilation.
- Do not use the machine when it is raining or during a thunderstorm.
- Never suck up fluids which contain solvents f. e. paint thinner, petrol, oil and acid or unfiltered water. The seals in the machine cannot withstand them. Moreover spray mist containing solvent is highly flammable, explosive and toxic!
- Never let the pump run longer than 1 minute without fluid.
- Do not let the pump operate longer than 10 minutes with the inlet valve and the main valve (or spray gun) closed and a flowing through of the fluid is therefore prevented; or also in the case the inlet valve is open and main valve is closed, but there is too little water left in the tank. The temperature of the circulating fluid in the pump will rise then quickly, creating a great risk of damaging the pump seals.
- Ensure that - if a petrol engine is applied - the fuel tank contains sufficient fuel to accomplish the intended spray activities.
- Never sucks water up from a drinking water tank.
- Never execute repair or maintain activities to the machine while it is operating.
- After the spraying work is finished, the operator must wash and clean him/herself and dress with other clothes.

Protection against chemicals

Vegetation of means of protection, disinfection, remedy or feeding are chemicals. They are meant to come into contact with only the vegetation.

Handle them carefully. Avoid contact with it (skin and air) because they can damage your health.

- Protection clothes are intended to prevent coming into contact with these chemicals.

Examples of protection clothes are:

- Gloves
- Boots
- Head protection
- Gas mask
- Safety glasses
- Overall, resistant to chemicals

- Protection clothes must be used during the making of the spray fluid, during the spray operation and during the cleaning of the spray equipment.

The protection clothes are especially useful to be protected against the rebound splashing of the spray fluid during spraying.

- Act always according to the instructions of the manufacturer or supplier of the used chemicals.
- This applies also to the instructions related to the wearing of necessary clothes for the operator as well as to the processing of the spray fluid, handling these chemicals.
- It is always useful to have clean water at hand (for washing), especially during and after supplying the tank with chemicals.
- Keep alert and maintain supervision; pay special attention preventing children and/or animals approaching and/or coming in contact with the chemicals, the equipment and/or the spray fluid.
- Go immediately to the (your) doctor or phone for an ambulance in the case of a possible poisoning by the chemicals.
- Don't smoke eat or drink during the spray operation because of the possible presence of chemicals in the air inducing the possibility to get it in.
- Clean the equipment immediately carefully, after the work is done.
- Wash tools which are affected with the spray fluid with clean water.

Change kind of chemicals

De spray equipment (tank, hose and pump etc., the outer as well as the inner side) must always be totally cleaned, before another chemical may be applied.

Filling

It is allowed to fill the tank from a drinking water system under the condition of the related local legal water regime or legislation.

In no case the pump may be connected directly to the public drinking water system (risk of contamination).

Electrical

To prevent the risk of an electrical shock:

- Never point the spray gun (or one of the other spray tools) on the equipment or on any other electrical apparatus or electrical current guiding parts.
- Never grab a connector with wet hands.

- Use shoes or boots with rubber soles, while working with the electrical equipment.
- Prevent the electrical cable to be damaged.
- Prevent insecure repairs.
- Never pull on the electrical cable to disconnect the connector (and so to turn off the machine).
- If an extension cable is used, it must be sufficient specified in relation to the required electrical power, even if it is not completely unwound when in use.

Traffic safety

When the equipment is riding on a public road, the local legal traffic rules must be kept for such a vehicle. This is specifically valid for the required illumination (when riding in dawn or darkness).

Operation

General

- Check the oil level of the pump; if necessary, top up.
- Check (if applicable) the amount of fuel, needed for the intended spray activities; if necessary, top up.
- Connect the high-pressure hose to the spray equipment and the high-pressure outlet of the pump.
- Ensure that the swivel nuts are firmly tightened (see also the safety requirements).
- Check the total assembly of the spray equipment.

To fill the main tank

- With the filling hose and/or the self-sucking pump, water is pumped to fill the tank.
- Use as clean as possible water.
- Use always the water filter, when filling the tank.
- Filling of the tank is done through the opening on the top of tank (generally closed with a cover) or with a special filling pipe (if this option is mounted).
- Turn on the pump only then, when the filling hose is placed in the (water) well / source (the part from the well to the pump) **and** when it is placed in de tank (the part **from** the pump to the tank).

Adding and mixing (dissolving) the chemicals

- Before adding the chemicals, the tank needs minimally to be filled with water up to **1/10** part of the total contents of the tank.
- At this, the instructions of the supplier or manufacturer of the chemicals must be followed.
- Top up the tank after adding these chemicals.
- The chemicals needs to be thoroughly mixed with/dissolved in the water.
- For this the pump must recycle the fluid du ring at least 15 minutes.
- Generally this is done by closing the main valve during that time. In this way recycling takes place automatically (fig. 2,3)
- If the optional mixing device is mounted, a separate valve must be opened (fig. 2,3)
- The open and close position of the handles are indicated at the photos in fig. 2,3.



Fig. 2

Inlet-valve feeding the pump; position 'closed'

Main valve feeding the spray unit position 'closed'

Main valve mixing device position 'closed'

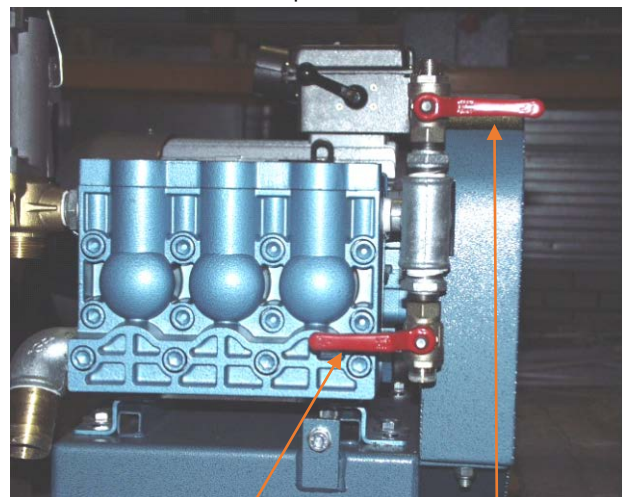

Fig. 3

Main valve feeding spray unit position 'closed'

Valve mixing device position 'closed'

- Flush out accurately used packaging a number of times; in this way they will become clean enough to be thrown away as normal waste. Use the special clean flushing for packaging device, if this is mounted.
- When the tank has been filled, turn off the pump, remove and store the filling hose and close the tank with the cover.
- Prevent an overflow of the tank (it may contaminate the environment).

Clean water tank (optional)

As an option a clean water tank can be placed (see fig. 4). The contents is 16 litres. It must be filled with clean water. The purpose of this water is: washing hands, cleaning of tools and other small odd jobs, with which clean water is needed (it is no drinking water).



Fig. 4



Main valve (feeding)
Pressure regulator
Distribution valve
Manometer
Release handle

Fig. 5

Start of spray activities

- Ensure a sufficient amount of spray fluid is available for the planned spray activity.
- Position the equipment stable on a suitable place.

In case of a tractor drive:

De apparatuur volgens de normale tractor voorschriften koppelen aan de tractor:

- Connect the unit at three points in accordance with the standard tractor instructions and secure the connecting pins.
- Check the connecting shaft, grease if necessary and fit it between the unit and the power take-off shaft in accordance with the appropriate user instructions.
- Set the speed of the power take-off shaft to a maximum of 540 rpm respect. 650 rpm (see type plate on pump/ machine)

- Be alert that all safety requirements related to a tractor drive are fulfilled. This especially applies the mechanical drive parts between the tractor and the spray equipment (the universal joints and the axial drive axle with lateral play). Set the 'release handle to the right,' on 'press'.

- Ensure the pressure regulator is set to the minimum pressure (the knob of the pr. reg. is completely turned anti-clockwise, fig. 6)

- Ensure the main valve is closed (fig. 6).

- Turn on the equipment (Options : start the electromotor / petrol engine / the tractor drive).

- Adjust the desired pressure with the pressure regulator (turn and adjust the knob clockwise).

To stop the spray activities

- To stop with the spray activities: first set the 'release handle to the left, to position 'by pass', adjust subsequently the pressure regulator to its minimum (turn the knob anticlockwise completely); then close the main valve and turn off the pump (electrical motor/ petrol engine / tractor drive).

Storage of the equipment

Take the right precautions to prevent freezing

- Take care that no fluid is left in the pump when the equipment is stored during the winter period.
- Preferably store the equipment, with its accessories, always in a room free of freezing.
- If freezing cannot be prevented for sure, the following action must be undertaken: the suction and press side of the pump must be opened, then the pump must run for at least 30 seconds. By this, all the possibly left fluid will be removed.

Use during a freezing period

Only if it is for sure that no fluid has been left in the pump, it is allowed to start the pump when it freezes. It means that the equipment was correctly stored.

If this was not the case and if the pump is turned on anyway, it may be blocked because of the building up of ice in it and may end up as broken (loss of time, cost).

Maintenance

General

To use maintaining the equipment trouble free, the condition of the parts and junctions needs regularly inspection and if necessary maintenance must be executed.

Always: remove the electrical plug during maintenance or repair activities.

Electrical

The inspection and repair (such as the replacement of worn or damaged cables and connectors) of electrical parts may only be accomplished by a certified professional.

The inspection of the electrical cable:

- Worn or damaged electrical cables must be replaced immediately.

Hydraulic parts, high pressure hoses etc.

The inspection and repair of hydraulic parts may only be accomplished by a certified professional.

Inspection of the high pressure hose:

- Worn or damaged high pressure hoses must be replaced immediately.

Pump and valves

Inspection on pump leakage:

- The pump must immediately be serviced by the supplier, if it has an oil- and/or fluid leakage of more than 3 drips a minute.

Inspection of the pump oil:

- Execute the inspection only if it is not running.
- Inspect the oil level; if necessary, fill up till the lever "MAX".
- The oil of the pump must be refreshed after the first 20 hours of operation and subsequently after every 150 hours of operation.
- The pump oil must anyhow be refreshed at least 2 times a year, regardless the number of hours of the operation.
- If the oil has a white, milky colour, this means it has water dissolved in it. Inspect the packing rings, membranes and oil sealing rings and where necessary replace them and change the oil.

Fluid (water) pump circuit

Inspection of the fluid (water) filter(s):

- To maintain an adequate supply of water, the water filters must regularly inspected on containment and if necessary be cleaned or replaced.

The version with the Honda petrol engine

For maintenance, failures etc. related to the version with a Honda petrol engine drive: see the Honda manual.



Fig. 6

Fault finding

Below an overview is given of the most frequently occurring fault or failures together with the possible causes and eventually solutions.

FAULT	CAUSE	SOLUTION
Insufficient pressure	Pump insufficiently ventilated	Ventilate
	Pump sucking in air	Check whether liquid in tank
		Check supply hose and connections
	Supply blocked	Check water filters
	Valves dirty or worn	Check, clean or replace
Water in oil	Packing rings or plungers leaking	Check, clean or replace
	V-belt slipping	Check, tighten or replace
	High air humidity	Check and double frequency of oil changes
Pump leaking liquid	Worn plunger seal and worn oil sealing ring	Check and replace
	Worn O-rings on plunger guide	Check and replace
Pump leaking oil	Oil level too high	Check and adjust
	Worn oil sealing ring	Check and replace
Motor does not start	Not properly plugged in or no power	Check the plug, cable and switch
Motor humming but not running	Insufficient mains power	Check power supply
	Incorrect cable extension	Replace with correct cable
	Pump jammed or frozen	Check by rotating the pump shaft a few times by hand
Motor stops running	Motor has cut out due to overheating	Check main power Switch off unit and leave to cool down for a few minutes

GC 50

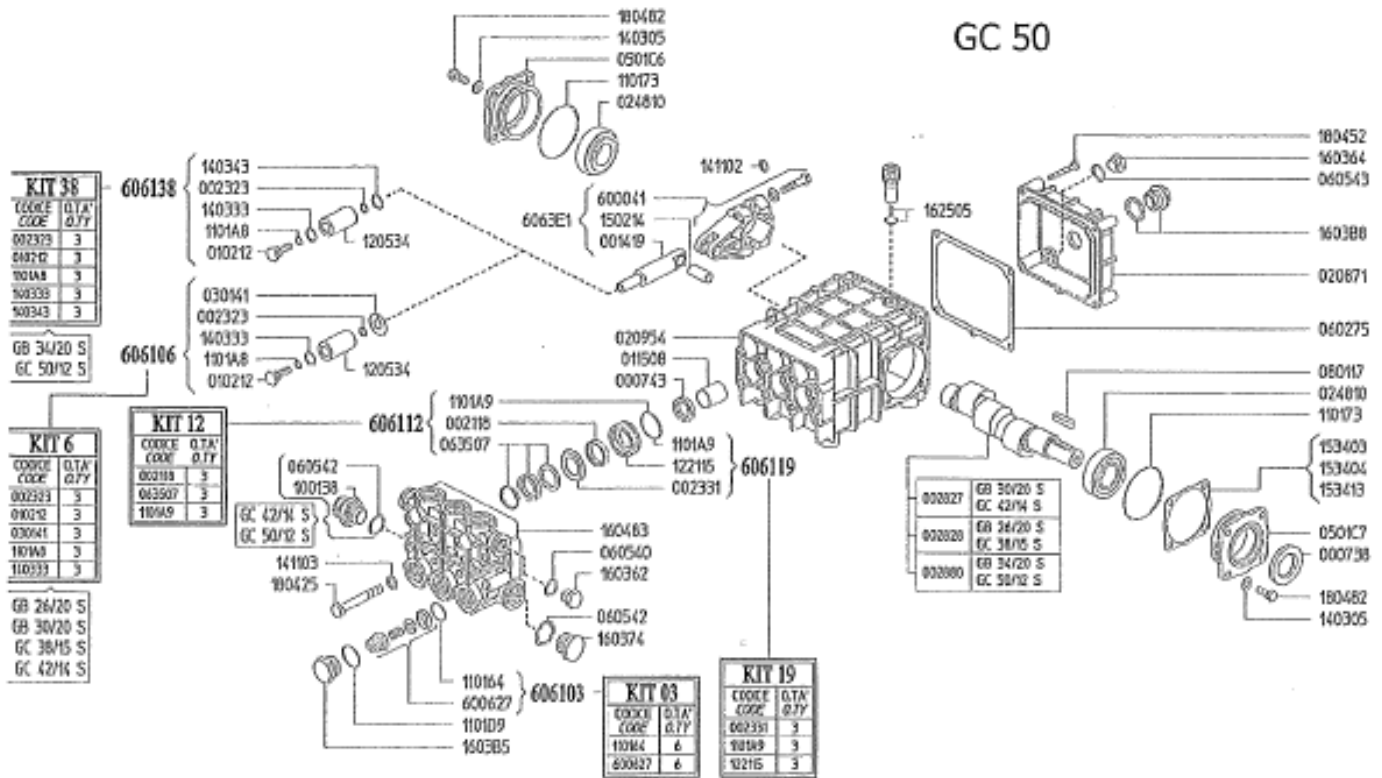

Code	Description	No Off
U0007.38	Oil Catcher	1
U0007.43	Oil Catcher	3
U0014.19	Crosshead	3
U0021.18	LP manchet	3
U0023.23	Ring	3
U0023.31	Manchering	3
U0028.80	Crankshaft	1
U0102.12	Tension Screw	3
U0115.08	Guiding sleeve	3
U0208.71	Crankcase cover	1
U0209.54	Crankcase	1
U0248.03	Bearing	2
U0501.06	Bearing cover closed	1
U0501.C7	Bearing cover open	1
U0602.75	Gland	1
U0605.40	Gland	1
U0605.42	Gland	1
U0605.43	Gland	1
U0801.17	Woodruff key	1
U1101.17	O-ring	6
U1101.64	O-ring	6
U1101.73	O-ring	2
U1101.A8	O-ring	3
U1101.A9	O-ring	3

Code	Description	No. Off
U1205.34	Plunger	3
U1221.15	Manchet sleeve	3
U1403.05	Closing ring	8
U1403.33	Ring	6
U1403.43	O-ring	3
U1411.03	Closing ring	8
U1502.14	Crosshead pin	3
U1534.03	Fitting ring 0,1 mm	
U1534.04	Fitting ring 0,2 mm	
U1534.13	Fitting ring 0,05 mm	
U1603.02	Oil Drain Plug	1
U1603.62	Plug	1
U1603.74	Plug	1
U1603.B5	Valve cover	6
U1603.B8	Oil inspection glass	1
U1604.83	Valve casing	3
U1625.05	Oil dipstick	6
U1804.25	Bolt	8
U1804.52	Bolt	4
U1804.82	Bolt	8
U6000.41	Crank rod	3
U6006.28	Valve-unit	6

Pos. Nr.	Code	Description	Q.TY
1	B24.0321.32	Snob	1
2	B24.0325.48	Spring 40 bar	1
2	B24.0316.48	Spring 50 bar	1
3	B24.0312.32	Lever	1
4	B24.0314.53	Guiding Piston	1
5	B85.1148.00	Pin 4 x 30	1
6	B80.3175.00	O-ring 2,62x10,78	1
7	B80.3075.00	O-ring 1,78x25,12	1
8	B86.1935.00	Screw	4

Pos. Nr.	Code	Description	Q.TY
9	B84.3539.00	Washer	4
10	B24.0311.32	Flange	1
11	B24.0313.36	Diaphragm	1
12	B24.0319.51	Valve	1
13	B86.1841.50	Screw	1
14	B24.0324.51	Valve seat	1
15	B80.3059.00	O ring 1,78x11,11	1
16	B24.0323.53	Valve body	1

DRAWING SPAREPARTS REGULATOR E.86.68.400 en E86.68.500

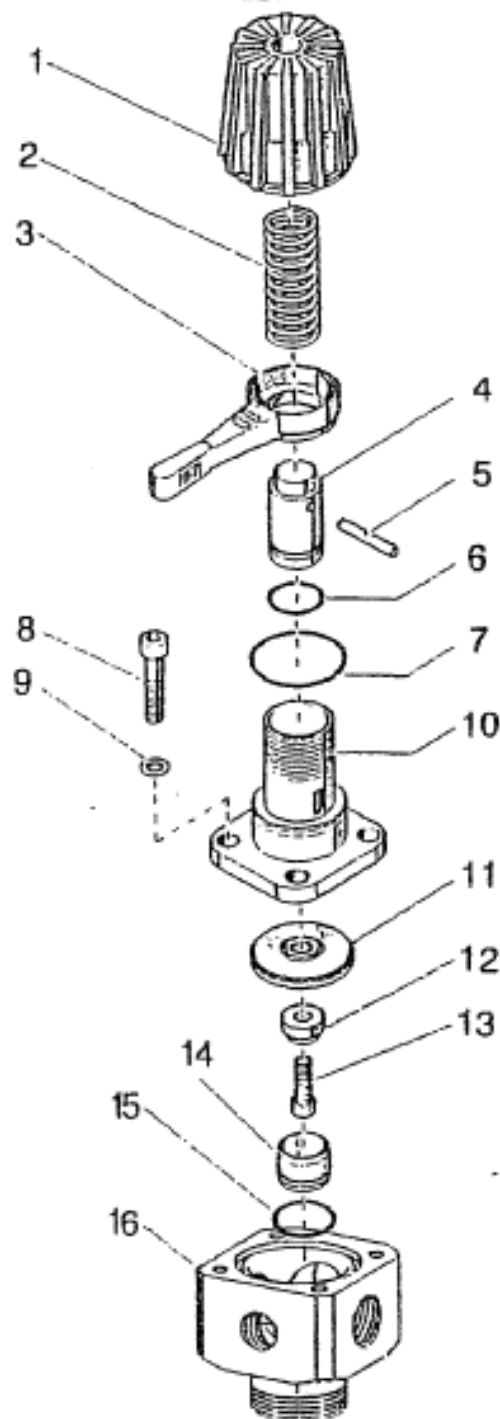

Ersatzteilverzeichnis UL 221
Spare Parts List ULH 221

Lfd. Nr. Item No.	Stückzahl No. Off	Best.-Nr. Code No.	Benennung	Description
1	1	01.0358	Gehäuse	Casing
2	1	07.0728	Führungsstopfen	Guide Plug
o-3	1	06.0272	O-Ring zu 2	O-Ring for 2
4	1	07.0804	Sechskantschraube mit Zapfen	Hexagon Screw with Journal
5	1	11.0339	Kolbenstange UL(H)221/100	Piston Rod UL(H)221/100
5	1	11.0126	Kolbenstange UL(H)221/140	Piston Rod UL(H)221/140
5	1	11.0126	Kolbenstange UL(H)221/200	Piston Rod UL(H)221/200
o-6	1	06.1161	O-Ring zu 5	O-Ring for 5
o-7	2	06.1248	Stützring zu 5	Support Ring for 5
8	1	07.0729	Kolbenkörper	Piston Body
o-9	1	06.0070	Manschette	Sleeve
o-10	1	07.0589	Manschettensstützring	Sleeve Support Ring
o-11	1	07.1059	Kugel für Bypassventil	Ball for Bypass Valve
o-12	1	07.1351	Rückschlagventilfeder	Kick-Back Valve Spring
o-12A	1	07.0901	Bypassventilfeder	Bypass Valve Spring
13	1	07.2767	Bypass-Ventilstopfen	Bypass Valve Plug
13A	1	07.1645	Ventilstopfen für Rückschlagventil	Valve Plug for Kick-Back Valve
o-13B	2	06.0247	O-Ring zu 13A	O-Ring for 13A
o-14	1	07.1344	Rückschlagventilkegel	Kick-Back Valve Taper
o-14A	1	06.0438	O-Ring zu 14	O-Ring for 14
o-15	1	07.1013	Bypassventilkörper	Bypass Valve Body
o-15A	1	07.1328	Rückschlagventilkörper	Kick-Back Valve Body
16	1	07.1057	Spiralfeder für 100 bar	Spiral for 100 bar
16	17	07.0633	Tellerfeder für 140 bar	Spring Plate for 140 bar
16	15	07.0906	Tellerfeder für 200 bar	Spring Plate for 200 bar
17	1	07.2022	Selbstsich. Sechskantmutter	Self Locking Hexagon Nut
18	1	07.0770	Scheibe	Disc
19	1	07.1560	Zentrierscheibe für Spiralfeder	Centring Disc for Spiral
19	1	07.0752	Stellmutter für Tellerfeder	Adjusting Nut for Spring Plate
20	4	07.3809	Verschlußstopfen	Plug
o-20A	4	06.0245	O-Ring zu 20	O-Ring for 20
21	1	07.2061	Distanzhülse UL221/100	Spacer Sleeve UL221/100
21	max. 5	07.0807	Distanzscheibe 1,0mm	Spacer Disc 1,0mm
21A	max. 5	07.2046	Distanzscheibe 0,2mm	Spacer Disc 0,2mm
22	1	07.0771	Handrad	Hand Wheel
*	1	14.0025	Reparatursatz	Repair Kit

bei Ausführung mit Handrad
entfällt Pos. 19 Stellmutter

Adjusting Nut (19) is not necessary
on hand wheel construction

Ersatzteilliste UL 221PL Ausf. Plattenrückschlag
Spare Parts List UL 221PL Plate Kick-Back Valve Version

o12	1	07.2781	Ventilfeder	Valve Spring
13A	1	07.3003	Ventilstopfen	Valve Plug
o14	1	07.3002	Ventilplatte	Valve Plate
o15A	1	07.3004	Ventilkörper	Valve Body
o	1	14.0531	Reparatursatz	Repair Kit

