



**ANNOVI
REVERBERI**
The Power of Experience

ANNOVI REVERBERI S.p.A.
Via M. L. King, 3 - 41100 Modena (Italy)
Tel. (+39) 059.414.411 - Fax (+39) 059.253.505
E - Mail: industria@annovireverberi.it

Pump type
Type de pompe
Pumpetyp
Tipo de bomba
Tipo pompa

XWA



TECHNICAL DATA / DONNEES TECHNIQUES / TECHNISCHE ANGABEN
CARACTERISTICAS TECNICAS / CARATTERISTICHE TECNICHE

PUMP TYPE TYPE DE POMPE PUMPETYP TIPO DE BOMBA TIPO POMPA	CAPACITY DEBIT LEISTUNG CAUDAL PORTATA		PRESSURE PRESSION DRUCK PRESION PRESSIONE		POWER PUISSANCE KRAFT POTENCIA POTENZA		RPM TOURS/1' U.P.M. REVOLUCIONES/1' N° GIRI/1'	WEIGHT POIDS GEWICHT PESO PESO
	l/min	gpm (US)	bar	psi	HP	kW		
XWA 4 G20 N	15,1	4	140	2000	5,5	4	1750	16
XWA 4 G30 N	15,1	4	205	3000	7,5	5,5	1750	16
XWA 5.5 G22 N	20,8	5,5	150	2200	7,5	5,5	1750	16
XWA 5.5 G30 N	20,8	5,5	205	3000	10	7,5	1750	16
XWA 5.5 G40 N	20,8	5,5	275	4000	14	10,5	1750	16
XWA 7 G22 N	25,5	7	150	2200	10	7,5	1750	16
XWA 7 G32 N	25,5	7	220	3200	14	10,5	1750	16
XWA 7 G35 N	25,5	7	240	3500	15	11	1750	16
XWA 7 G40 N	25,5	7	275	4000	17	12,5	1750	16
XWA 8 G19 N	30,2	8	130	1900	10	7,5	1750	16
XWA 8 G29 N	30,2	8	200	2900	15	11	1750	16
XWA 8 G35 N	30,2	8	240	3500	18	13,4	1750	16
XWA 9 G16 N	34	9	110	1600	10	7,5	1750	16
XWA 9 G24 N	34	9	170	2400	15	11	1750	16
XWA 9 G30 N	34	9	205	3000	18	13,4	1750	16



ATTENTION:
ATTENZIONE:
ACHTUNG:
ATENCIÓN:
ATTENZIONE:

- This manual must be read before beginning installation of the unit.
- Ce livret doit être lu avant d'installer et d'employer le produit.
- Das vorliegende Handbuch ist vor der Installation und dem Gebrauch des Produkts aufmerksam zu lesen.
- Este manual debe ser leído antes de proceder a la instalación y uso del producto.
- Il presente libretto va letto prima di procedere all'installazione ed uso del prodotto.

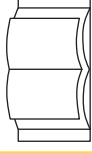

cod. 00630_XWA

XWA

VERSION

N

1750rpm

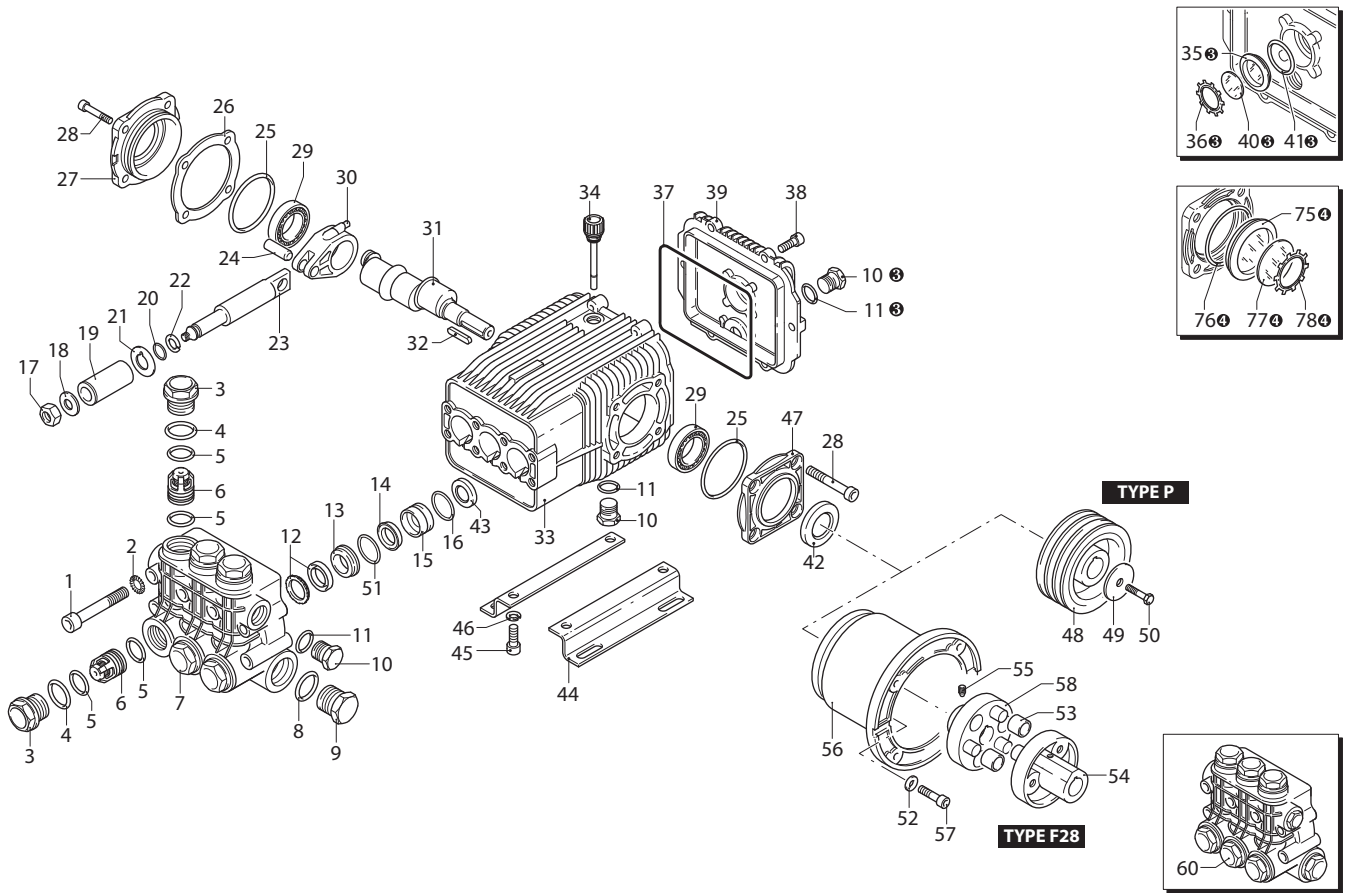

UN002609-AV

KIT RICAMBI / PART KITS

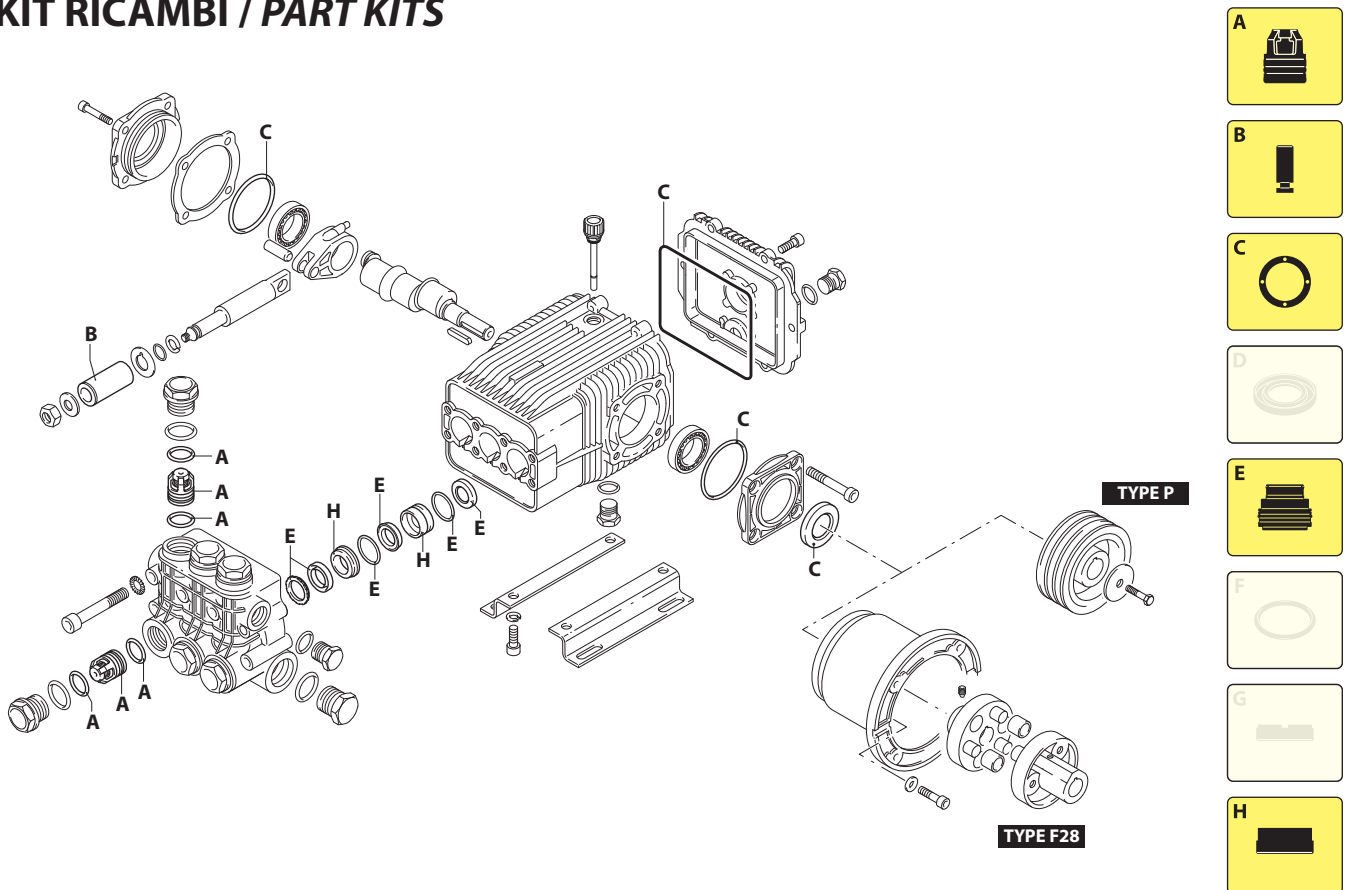

UN002610-AV

XWA

VERSION N

MODELLO - MODEL:

4 G20	4 G30	5.5 G22	5.5 G30	5.5 G40
7 G22	7 G32	7 G35	7 G40	8 G19
8 G29	8 G35	9 G16	9 G24	9 G30



Pos.	Cod. Part n°	Denominazione	Description	Q.tà Q.ty	Note Vedi / See	Pos.	Cod. Part n°	Denominazione	Description	Q.tà Q.ty	Note Vedi / See
1	1940260	Vite TCEI M 10x80	Screw	8	⊗ 50 Nm	32	650250	Linguetta	Key	1	
2	650530	Rosetta	Washer	8		33	1941330	Corpo pompa	Pump housing	1	
3	1940140	Tappo	Plug	6	⊗ 68 Nm	34	1140370	Tappo olio	Oil cap	1	
4	1940150	Anello	Ring	6		35	1260250	Livello olio	Oil indicator	1	⊗
5	1140450	OR Ø 20,24x2,62	O-Ring	12		36	1260430	Anello elastico	Snap ring	1	⊗
6	1949050	Valvola completa	Complete valve	6		37	1940410	OR Ø 132x3	O-Ring	1	
7	1940021	Testa pompa	Pump head	1	● ○ ■	38	1200430	Vite TCEI M 6x16	Screw	6	
	1941210	Testa pompa	Pump head	1	▲ ◆	39	1949010	Cop. post. compl.	Complete cover	1	
8	550350	OR Ø 23,81x2,62	O-Ring	1		40	1780690	Disco di contrasto	Disc	1	⊗
9	1140300	Tappo 3/4" G	Plug	1		41	1140450	OR Ø 20,24x2,62	O-Ring	1	⊗
10	1980740	Tappo 3/8" G	Plug	3	⊗	42	820680	Anello tenuta	Seal	1	
11	740290	OR Ø 14x1,78	O-Ring	3	⊗	43	1940560	Anello tenuta	Seal	3	
12	1940440	Guarn.+anello	Gasket w/ ring	3	Ø 20 ● ○ ■ ▲	44	1940370	Piede	Base	2	Optional
	1940270	Guarn.+anello	Gasket w/ ring	3	Ø 22 ◆	45	1940380	Vite TCEI M 10x18	Screw	4	Optional
13	1940430	Guida pist. ant.	Front piston guide	3	Ø 20 ● ○ ■ ▲	46	200231	Rosetta	Washer	4	Optional
	1940200	Guida pist. ant.	Front piston guide	3	Ø 22 ◆	47	1941240	Supporto aperto	Open bearing sup.	1	
14	1940470	Guarnizione	Gasket	3	Ø 20 ● ○ ■ ▲	48	1940290	Puleggia	Pulley	1	
	1940480	Guarnizione	Gasket	3	Ø 22 ◆	49	780230	Rondella	Washer	1	
15	1940450	Guida pist. post.	Rear piston guide	3	Ø 20 ● ○ ■ ▲	50	780060	Vite TCEI M 6x25	Screw	1	
	1940460	Guida pist. post.	Rear piston guide	3	Ø 22 ◆	51	1941220	OR Ø 22x2	O-Ring	3	Tagliato/Cutted
16	820490	OR Ø 34,65x1,78	O-Ring	3		52	390311	Rondella Øi 8,5	Washer	4	
17	1940570	Dado	Nut	3	⊗ 12 Nm	53	1321670	Boccola	Bushing	6	
18	1940580	Rosetta	Washer	3		54	1380340	Semigiunto motore	Motor coupling	1	
19	1420430	Pistone	Piston	3	Ø 20 ● ○ ■ ▲	55	1380180	Grano M 6x10	Grub screw	2	
	1420120	Pistone	Piston	3	Ø 22 ◆	56	1940890	Flangia motori B3/B14	El. motor flange	1	B3/B14
20	880840	OR Ø 9,25x1,78	O-Ring	3		57	620610	Vite TCEI M 8x30	Screw	4	
21	960460	Disco separatore	Spacer	3		58	1940870	Semigiunto pompa	Pump coupling	1	
22	1940120	Anello	Ring	3		59	1949200	Prem.testa	Head pre-assembly	1	Ø 20 ■ ▲
23	1940070	Pistone di guida	Guiding piston	3		60	1949202	Prem.testa	Head pre-assembly	1	Ø 20 ▲
24	1940060	Spinotto	Piston pin	3			1949203	Prem.testa	Head pre-assembly	1	Ø 22 ◆
25	1941380	OR Ø 66,34x2,62	O-Ring	2		75	1941270	Livello olio	Oil indicator	1	⊗
26	1941390	Spessore 0,05 mm	0,05 mm shim	1÷3		76	100410	OR Ø 34,6x2,62	O-Ring	1	⊗
	1941400	Spessore 0,10 mm	0,10 mm shim	1÷3		77	1941260	Disco di contrasto	Disc	1	⊗
	1941410	Spessore 0,19 mm	0,19 mm shim	1÷3		78	1941290	Anello elastico	Snap ring	1	⊗
	1941420	Spessore 0,25 mm	0,25 mm shim	1÷3							
27	1949011	Coperchio lat. compl.	Compl. side cover	1							
28	850370	Vite TCEI M 8x16	Screw	8							
29	1140410	Cuscinetto	Bearing	2							
30	1940050	Biella	Con-rod	3							
31	1940530	Albero eccentrico	Crank shaft	1	●						
	1940190	Albero eccentrico	Crank shaft	1	○						
	1940170	Albero eccentrico	Crank shaft	1	■						
	1940160	Albero eccentrico	Crank shaft	1	▲ ◆						

⊗ Compreso nel cod. 1949010 / Part of part n° 1949010

⊗ Compreso nel cod. 1949011 / Part of part n° 1949011

KIT RICAMBI - PART KITS

A=KIT 2780 valvole valves		B=KIT 2650 Ø 20 pistoni pistons		B=KIT 1891 Ø 22 pistoni pistons		C=KIT 2873 tenute olio oil seals	
Pos.	Q.ty	Pos.	Q.ty	Pos.	Q.ty	Pos.	Q.ty
5	6	19	3	19	3	25	2
6	6					37	1
						42	1
						43	3

SIMBOLOGIA - SYMBOLS

- Per / For XWA 4 G20 XWA 4 G30
- Per / For XWA 7 G22 XWA 7 G32 XWA 7 G35 XWA 7 G40
- ▲ Per / For XWA 8 G19 XWA 8 G29 XWA 8 G35
- ◆ Per / For XWA 9 G16 XWA 9 G24 XWA 9 G30
- Per / For XWA 5.5 G22 XWA 5.5 G30 XWA 5.5 G40

⊗ = Coppia serraggio (Tolleranza +0 / -10% Nm)

⊗ = Torque wrench (Allowance +0 / -10% Nm)

E=KIT 2782 Ø 20 tenute acqua water seals		E=KIT 2783 Ø 22 tenute acqua water seals		H=KIT 2784 Ø 20 guida pistoni pistons guide		H=KIT 2785 Ø 22 guida pistoni pistons guide	
Pos.	Q.ty	Pos.	Q.ty	Pos.	Q.ty	Pos.	Q.ty
12	3	12	3	13	3	13	3
14	3	14	3	15	3	15	3
16	3	16	3				
51	3	51	3				

PARTI SPECIALI IN VITON SPECIAL PARTS

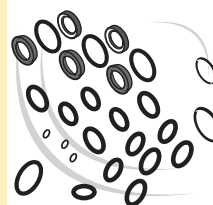

Cod. Part n°	Denominazione Description	Q.tà Q.ty
2778	Tenute acqua/Water seals Ø 20	1
2779	Tenute acqua/Water seals Ø 22	1

GB TORQUE WRENCH SETTINGS

For the torque wrench see spare parts page list.

LUBRICATION

Before starting the pump, check the oil level in the pump. 0,9 kg of "SAE 30W" is to be used. Change the oil after the first 50 working hours and then after every 500 working hours.

F COUPLES DE SERRAGE

Pour les couples de serrage voir liste page rechanges.

LUBRIFICATION

Avant la mise en service de la pompe s'assurer que l'huile dans le carter soit à son juste niveau. L'huile à utiliser est "SAE 30W" 0,9 kg. Changer l'huile après les premières 50 heures de fonctionnement et successivement toutes les 500 heures de travail.

D ANZUGSMOMENTE

Für Anzugsmomente siehe Ersatzteilliste.

SCHMIERUNG

Vor der Inbetriebnahme der Pumpe Ölstand im Kurbelgehäuse überprüfen. Zur Ölfüllung 0,9 kg "SAE 30W" verwenden. Ölwechsel nach den ersten 50 Betriebsstunden und dann alle 500 Betriebsstunden vornehmen.

E PARES DE TORSION

Para los pares de torsión ver la lista pagina repuestos.

LUBRICACION

Antes de poner en funcionamiento la bomba asegurarse que el nivel de aceite en el carter sea justo. El aceite que debe utilizarse es "SAE 30W" en la cantidad de 0,9 kg. Cambiar el aceite después de las primeras 50 horas de funcionamiento y sucesivamente cada 500 horas de trabajo.

I COPPIE DI SERRAGGIO

Per le coppie di serraggio vedere distinta pagina ricambi.

LUBRIFICAZIONE

Prima dell'avviamento della pompa assicurarsi che l'olio nel carter sia al giusto livello. L'olio da usare è "SAE 30W" nella quantità di 0,9 kg. Sostituire l'olio dopo le prime 50 ore di funzionamento e successivamente ogni 500 ore di lavoro.

DIMENSIONS / DIMENSIONES / ABMESSUNGEN / DIMENSIONES / DIMENSIONI