

DIMENSIONI D'INGOMBRO - OVERALL DIMENSION

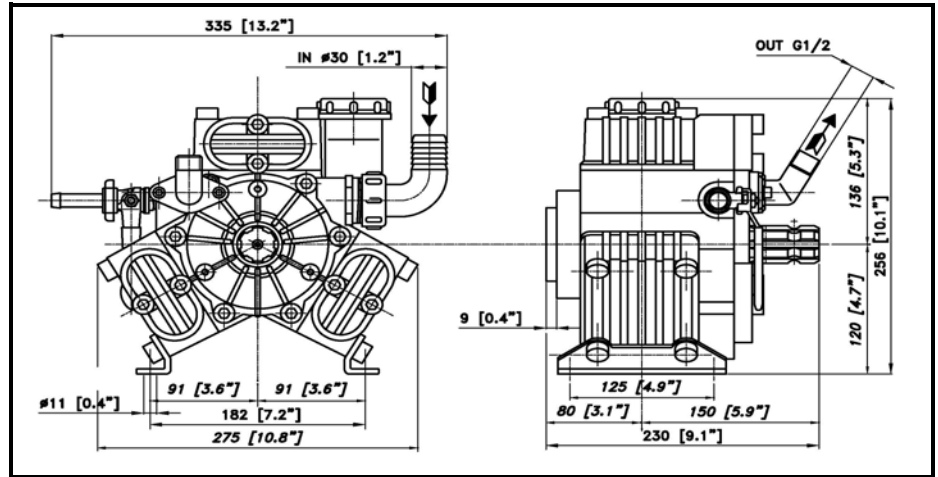

ALBERO POMPA - PUMP SHAFT

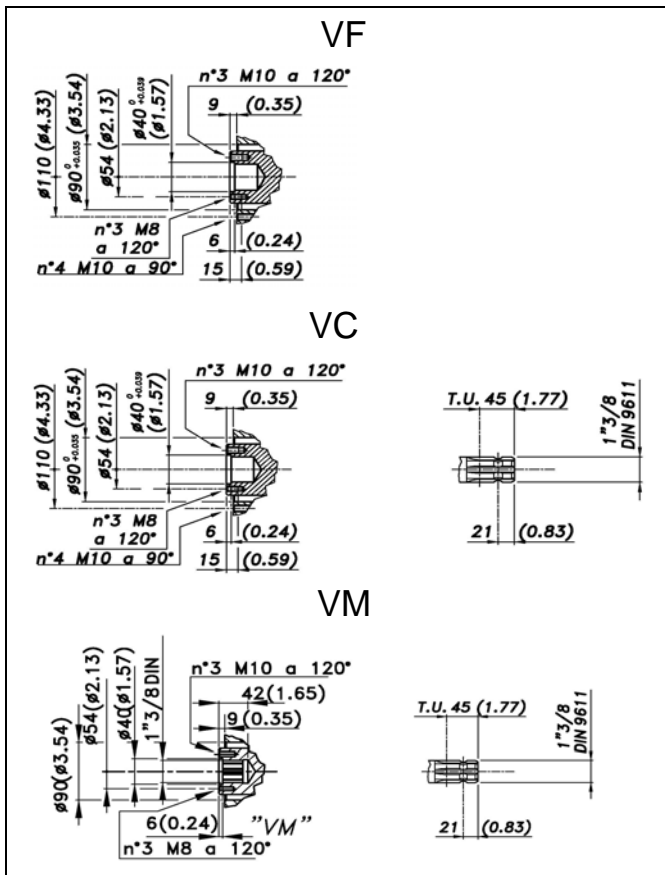

COPPIA DI SERRAGGIO - TORQUE CHART

CODICE - CODE	Q.TY	POS	N.m	Lbr.ft
23.0015.51.2	3	4	12	8.9
86.2168.00.2	2	40	10	7.4
86.2216.00.2	6	39	10	7.4
86.2730.00.2	2	28	10	7.4
86.3185.00.2	4	18	22	16.2
86.3300.00.2	6	48	44	32.5
86.3560.00.2	8	46	44	32.5
86.3562.00.2	4	32	44	32.5
23.0043.98.3	3	4	12	8.9

Tolleranza di serraggio: 0/-10%
 Tolerance on torque value:

KIT MEMBRANE - DIAPHRAGMS KIT

KIT	BUNA - N		DESMOPAN		VITON							PENTAX	
	23.9826.97.3	23.9873.97.3	23.9826.97.3	23.9826.97.3	1	44	45	49	50	36	37	23.9875.97.3	1
POSIZIONE ESPLOSO POSITION NUMBER	1	45	1	45	1	44	45	49	50	36	37	1	45
QUANTITA' NEL KIT QUANTITIES INCLUDED	3	6	3	6	3	1	6	6	6	1	1	3	6

KIT POMPA/KIT VALVOLE - PUMP KIT/VALVES KIT

KIT	KIT POMPA VM PUMP KIT VM							23.9829.97.3	KIT VALVOLE VALVE KIT		
	23.9880.97.3	35	19	44	45	49	50		36	37	2
POSIZIONE ESPLOSO POSITION NUMBER	1	1	1	6	6	6	1	1	6	6	6
QUANTITA' NEL KIT QUANTITIES INCLUDED	1	1	1	6	6	6	1	1	6	6	6

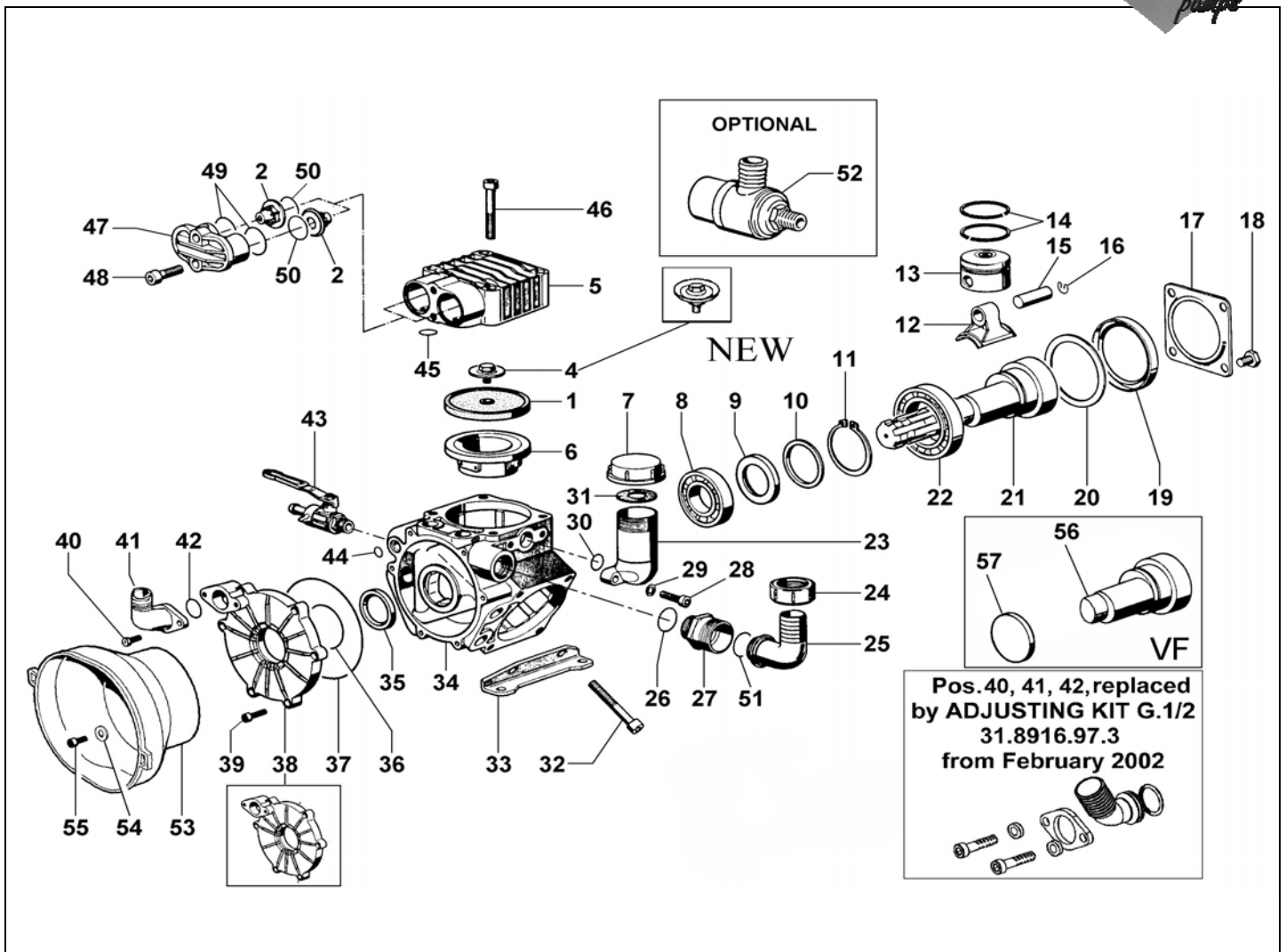

POS.	CODICE PART NO. REF.	DENOMINAZIONE - DESCRIPTION - DESCRIPTION	Q.TY
1	23.0011.31.2	PISTON DIAPHRAGM	3
1	23.0011.33.2	VITON PISTON DIAPHRAGM	3
1	23.0011.00.2	HPS PISTON DIAPHRAGM	3
1	23.0011.36.2	DESMOPAN PISTON DIAPHRAGM	3
2	23.9805.97.3	VALVE ASSY	6
4	23.0043.98.3	KIT DIAPHRAGM WASHER/SCREW AISI 316	3
4	23.0015.51.3	VITE MEMBRANA fino al 12/98	3
4	23.0009.32.2	PIATTELLO fino al 12/98	3
5	23.0002.09.2	HEAD	3
6	23.0020.01.2	PISTON SLEEVE D.55	3
7	85.2750.00.2	OIL FILLER CAP	1
8	81.2846.00.2	BALL BEARING DIA.35x72x17	1
9	23.0019.76.2	RING	1
10	26.0047.76.2	RING	1
11	80.1377.00.2	RING DIA.55 "VF"- "VC"- "VM"	1
12	23.0005.09.2	LIGHT ALLOY CONROD	3
12	23.0045.11.2	BRONZE CONROD	3
13	23.0007.09.2	PISTON D.55	3
14	81.8504.50.2	PISTON RING	6
15	85.2006.70.2	PISTON PIN DIA.15	3
16	80.0021.00.2	RING DIA.15	6
17	17.0013.61.2	COVER	1
18	86.3185.00.2	SCREW M10x16 UNI5739	4
19	80.2264.10.2	OIL SEAL DIA.68x90x10 "VF"- "VC"- "VM"	1
19	80.2156.00.2	COVER "VS"	1
20	17.0024.76.2	SPACER	1
21	23.0023.26.2	CRANKSHAFT VERSION "VC"	1
21	23.0024.26.2	CRANKSHAFT VERSION "VM"	1
21	23.0036.26.2	CRANKSHAFT VERSION "VS"	1
22	81.2972.00.2	BALL BEARING DIA.55x90x18 ("VM"- "VD")	1
23	23.0008.32.2	OIL FILLER	1
24	82.0067.50.2	WING NUT G.1"1/4	1
25	84.0560.00.2	90° ELBOW CONNECTOR DIA.30	1
25	84.0565.00.2	90° ELBOW CONNECTOR DIA.32 (OPTIONAL)	1
26	80.3207.00.2	O-RING 2,62x29,82	1
27	83.5089.00.2	NIPPLES G.1"-G.1"1/4	1
28	86.2730.00.2	SCREW M8x30 UNI5931	2
29	84.3685.00.2	WASHER DIA.8,4x15x1,5	2
30	80.3180.00.2	O-RING 2,62x15,08	1

POS.	CODICE PART NO. REF.	DENOMINAZIONE - DESCRIPTION - DESCRIPTION	Q.TY
31	82.4120.00.2	GASKET DIA.45x19x1,5	1
32	86.3562.00.2	SCREW M10x70 UNI 5931	4
33	23.0018.61.2	MOUNTING BRACKETS	2
34	23.0001.09.2	CRANKCASE	1
35	80.2134.50.2	OIL SEAL DIA.35x47x7	1
36	80.3209.80.2	O-RING 2,62x50,47	1
37	80.3210.68.2	O-RING 2,62x120,32	1
38	23.0046.09.2	CRANKCASE COVER	1
38	23.0006.09.2	CRANKCASE COVER till the 6/99	1
39	86.2216.00.2	SCREW M6x25 UNI5931	6
40	86.2168.00.2	SCREW M6x22 UNI5931	2
41	31.1003.09.2	90° ELBOW G.1/2 FITTING	1
41	31.1444.09.2	90° ELBOW 1/2"NPT FITTING (OPTIONAL)	1
41	31.8916.97.3	ADJUSTING KIT G.1/2	1
41	31.8918.97.3	ADJUSTING KIT 1/2 NPT (OPT)	1
42	80.3218.00.2	O-RING 3,0x22	1
43	84.5544.10.2	LEFT TAP G.3/8-G.1/2	1
44	80.3176.00.2	O-RING 2,62x11,91	1
45	80.3189.00.2	O-RING 2,62x18,72	6
46	86.3560.00.2	SCREW M10x65 UNI 5931	8
47	23.0003.09.2	VALVE COVER	3
48	86.3300.00.2	SCREW M10x30 UNI5931	6
49	80.3219.20.2	O-RING 3,0x35	6
50	80.3207.00.2	O-RING 2,62x29,82	6
51	80.3219.00.2	O-RING 3,0x25	1
52	24.3040.97.3	SAFETY VALVE 40bar (OPTIONAL)	1
53	31.1467.32.2	SAFETY CONE (OPTIONAL)	1
54	84.3618.00.2	WASHER DIA.6,4x18x1,5 (OPTIONAL)	3
55	86.2086.00.2	SCREW M6x14 UNI5931 (OPTIONAL)	3
56	23.0028.26.2	CRANKSHAFT VERSION "VF"	1
57	80.2099.50.2	COVER "VF"	1