

POLY 2116 - 2136 VS (1"3/8 M)

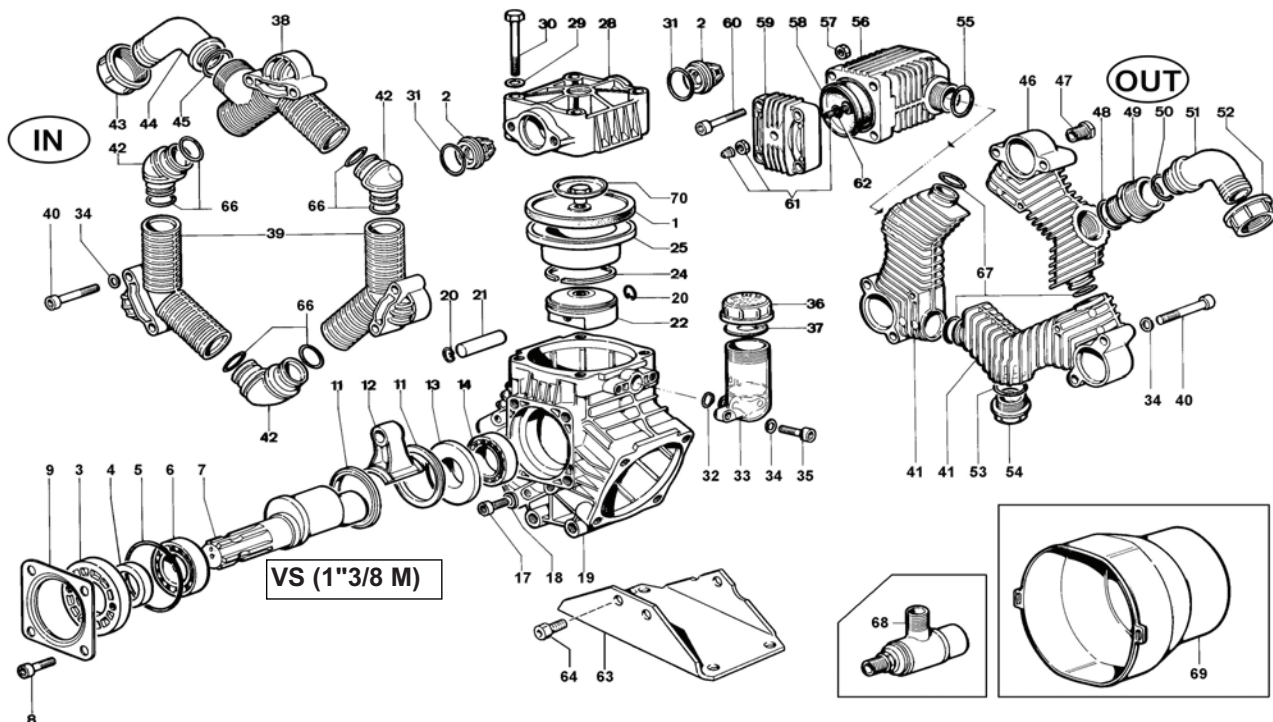

VERSIONI

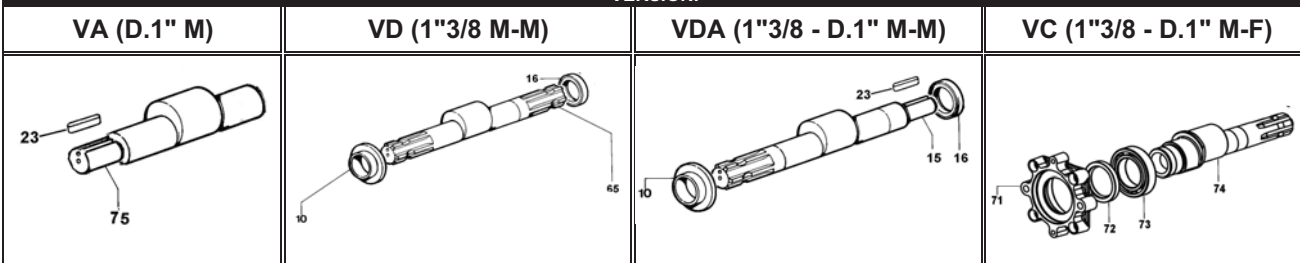

POS.	CODICE PART NO. REF.	DENOMINAZIONE - DESCRIPTION - DESCRIPTION	Q.TY	POS.	CODICE PART NO. REF.	DENOMINAZIONE - DESCRIPTION - DESCRIPTION	Q.TY
1	62.0040.00.2	DESMOPAN PISTON DIAPHRAGM	3	40	86.2960.00.2	SCREW M8x65 UNI5931	12
1	62.0040.31.2	BUNA-N PISTON DIAPHRAGM (OPTIONAL)	3	41	62.0002.32.2	MANIFOLD PIPE (OUTLET)	2
1	62.0040.33.2	VITON PISTON DIAPHRAGM (OPT.)	3	42	62.0007.32.2	ELBOW MANIFOLD	3
1	62.0040.36.2	HPS PISTON DIAPHRAGM (OPT.)	3	43	82.0070.00.2	WING NUT G.1"1/2	1
2	28.9809.97.3	S.S. VALVE ASSY	6	44	84.0591.00.2	90° ELBOW CONNECTOR DIA.40-1,57"	1
3	53.0007.32.2	HOUSING	1	44	84.0571.00.2	90° ELBOW CONNECTOR DIA.38-1,49" (OPT.)	1
4	80.2143.10.2	OIL SEAL DIA.35x52x7	1	45	80.3219.10.2	O-RING 3,0x30	1
5	80.3310.00.2	O-RING 4.0X82	1	46	62.0031.32.2	MANIFOLD PIPE G.3/8	1
6	81.2846.00.2	BEARING DIA.35x72x17	1	47	85.2576.00.2	CAP G.3/8	1
7	62.0010.26.2	CRANKSHAFT 1"3/8 "VS"	1	48	80.3219.10.2	O-RING 3,0x30	1
8	86.3187.50.2	SCREW M10x18 UNI5931	4	48	80.3219.15.2	O-RING 3,0x30 (KIT VITON)	1
8	86.3264.00.2	SCREW M10x25 UNI5931	4	49	83.5089.00.2	NIPPLES G.1"-G.1"1/4	1
9	17.0016.61.2	FLANGE	1	50	80.3219.00.2	O-RING 3,0x25	1
10	62.0029.09.2	SPACER CRANKSHAFT "VD"	1	51	84.0542.40.2	90° ELBOW CONNECTOR DIA.25-1"	1
11	98.0047.76.2	CONNECTING ROD RING	2	51	84.1608.40.2	STRAIGHT CONNECTOR DIA.25-1" (OPT.)	1
12	62.0008.11.2	CONROD	3	52	82.0067.50.2	WING NUT G.1"1/4	1
13	28.0027.09.2	SHAFT SPACER	1	53	80.3206.00.2	O-RING 2,62x28,25	1
14	81.2837.00.2	BEARING DIA.35x62x14	1	53	80.3206.50.2	O-RING 2,62x28,25 (KIT VITON)	1
15	62.0027.26.2	CRANKSHAFT "VDA"	1	54	85.2720.00.2	CAP G 1"	1
16	80.2143.10.2	OIL SEAL DIA.35x52x7	1	55	80.3219.10.2	O-RING 3,0x30	1
17	86.3694.50.2	SCREW M12x20 UNI5931	1	55	80.3219.15.2	O-RING 3,0x30 (KIT VITON)	1
18	82.4079.00.2	GASKET DIA.13,2x17x1 COPPER	1	56	27.0035.32.2	DAMPER BODY	1
19	62.0001.09.2	CRANKCASE "VS"	1	57	81.4574.50.2	NUT M8 UNI5588	4
19	62.0030.09.2	CRANKCASE "VD"- "VDA"- "VC"	1	58	23.0041.31.2	BALLASTER DIAPHRAGM	1
20	80.0021.00.2	RING DIA.15	6	58	23.0041.36.2	HPS BALLASTER DIAPHRAGM	1
21	85.2006.70.2	PISTON PIN DIA.15	3	58	23.0041.33.2	VITON BALLASTER DIAPHRAGM	1
22	62.0018.09.2	PISTON DIA.78 (POLY 2136)	3	59	11.0004.09.2	BALLASTER COVER	1
22	63.0013.09.2	PISTON DIA.72 (POLY 2116)	3	60	86.2752.10.2	SCREW M8x35 UNI5931	4
23	80.6475.00.2	TAB 6,36x6,36x38	1	61	86.1608.50.2	AIR VALVE	1
24	81.8540.00.2	PISTON RING DIA.78 (POLY 2136)	3	62	80.3213.00.2	O-RING 3,0x6	1
24	81.8530.00.2	PISTON RING D.72 (POLY 2116)	3	63	63.0006.61.2	MOUNTING RAIL	1
25	62.0019.01.2	PISTON SLEEVE (POLY 2136)	3	64	86.3255.00.2	SCREW M10x25 UNI5739	3
25	62.0005.01.2	PISTON SLEEVE DIA.72 (POLY 2116)	3	65	62.0024.26.2	CRANKSHAFT "VD"	1
28	62.0025.32.2	HEAD	3	66	80.3206.00.2	O-RING 2,62x28,25	6
29	84.3844.50.2	WASHER DIA.12,2x21x2,5	12	66	80.3206.50.2	O-RING 2,62x28,25 (KIT VITON)	6
30	86.4068.00.2	SCREW M12x75 UNI5931	12	67	80.3217.00.2	O-RING 3,0x19	3
31	80.3314.00.2	O-RING 4,5x40	6	67	80.3217.50.2	O-RING 3,0x19 (KIT VITON)	3
31	80.3314.50.2	O-RING 4,5x40 (KIT VITON)	6	68	24.3016.97.3	SAFETY VALVE 15bar (OPTIONAL)	1
32	80.3180.00.2	O-RING 2,62x15,08	1	69	31.1468.32.2	PLAIN SAFETY CONE (OPTIONAL)	1
33	23.0008.32.2	OIL FILLER	1	69	31.1482.32.2	PLAIN SAFETY CONE (OPTIONAL)	1
34	84.3685.50.2	WASHER DIA.8,2x15x1,5	14	70	62.9811.97.3	KIT SCREW/DISK INOX (POLY 2136)	3
35	86.2730.50.2	SCREW M8x30 UNI5931	2	70	62.9818.97.3	KIT SCREW/DISK INOX (POLY 2116)	3
36	85.2750.00.2	OIL FILLER CAP	1	71	62.0107.07.2	BALL BEARING HOLDER (VC)	1
37	82.4120.00.2	GASKET DIA.45x19x1,5	1	72	80.2191.10.2	OIL SEAL DIA. 45x62x7 (VC)	1
38	62.0004.32.2	MANIFOLD PIPE G.1"1/2	1	73	81.2933.00.2	BALL BEARING 6009 (VC)	1
39	62.0003.32.2	MANIFOLD PIPE	2	74	62.0108.26.2	CRANKSHAFT "VC"	1
				75	62.0022.26.2	CRANKSHAFT "VA"	1